

# **Bead Bazooka® ( Gaither's BB3LM / BB6LM / BB9LM / BB12LM )**

## **Replacement Parts list**

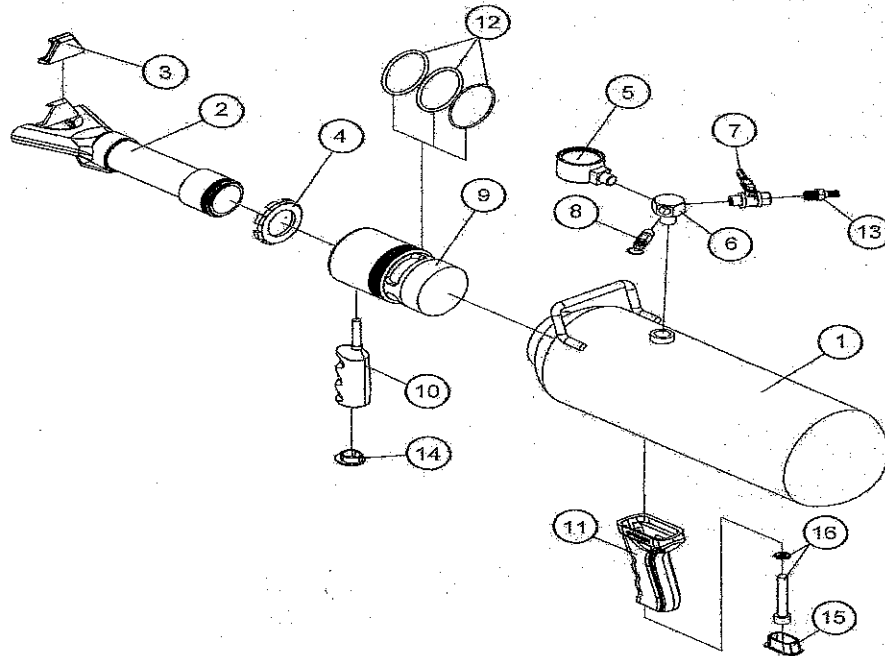

<u>Ref. No.</u>	<u>Part No.</u>	<u>Description</u>
1.	12910M	Air Tank
2.	12913M	1.5" Slotted Barrel w/ 2" Connector
3.	12927M	Plastic Protector
4.	12912M	( 50.8 mm ) 2" Lock Nut
5.	12914M	1.5" Pressure Gauge 10Bar
6.	12930M	F 1/4" x3 & M 1/4"x1 Connector
7.	12916M	( 6.35 mm ) 1/4"PT Intake Valve
8.	12917M	Safety Valve Max 10Bar
9.	12931M	2 Inch MIS Valve
10.	12932M	Tommy Gun Grip
11.	12920M	Grip
12.	12933M	2 pcs Square & 1pc O-Ring / set.
13.	12927	Universal Connector
14.	12934M	Round Plastic Plug
15.	12935M	Oval Plastic Plug
16.	12936M	M10 Bolt w/ Washer

## **Bead Bazooka® Accessories**

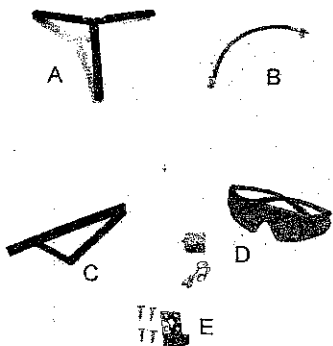

- A. GB-51 KD-Tire Stand
- B. GB-52 Air-Whip Hose
- C. GB-53 Tire Wedge
- D. GB-54 Safety Pack  
( goggles & ear plugs )
- E. GB-56 Wide Wall Clip w/4 screws

### **CAUTION:**

It is best to use clean / filtered compressed air to fill all Bead Bazooka® / Bead Booster® inflation tools. Unfiltered or unclean compressed air may poor performance and shorten the life of the product.

Gaither recommends this Bead Bazooka® tank be replaced after 5 years.