



LIFTOFF

Leading the lifting game since 2002



We  Jacks

Workshop Essentials

 USA 2025 V1





Reaching new Heights

We are a manufacturer, developer and supplier of top-quality, efficient, and dependable automotive workshop essentials. Our products are competitively priced and supported by exceptional customer service and support.

Our Focus

In the coming years, our primary focus will be on lifting, handling, and transportation safety. We understand the challenges mechanics face, both in workshops and on the road. As the quantity of heavy items (both vehicles and their commodities) increases, we believe it is our responsibility to supply cost-effective solutions that will save time and significantly reduce any risk.

Our second focus is ease of use. Our products are known to be operator-friendly and excel in ergonomics.

Winntec products are designed & manufactured in compliance with NEN-EN 1494:2001+A1:2008 CE UK .

Our History

In 2002 we decided to rebuild the hydraulic floor jack from the ground up. The result was an innovative, operator-friendly, and service-friendly design that skillfully combines European and American features and functionality.

Since then, Winntec has been broadening its range and it introduced various gamechanging technologies, including Turbo Lift and Auto Shift. Today, our products are available in over 60 countries worldwide.



Certain items are only available upon request in the USA. Throughout the brochure we have made a clear distinction between items that are immediately available and those that are only available upon request.

For more information, please visit www.winntec.net, give us a call on 217-245-0545 or send an email to usa@winntec.net.

Wheel Handling

Y471147HD3 Classic - Smart Cart

The original Smart Cart that changed the industry!

This long life, light weight, high capacity cart allows the tire fitter to maneuver heavy wheel sets in the most ergonomic way with the help of its PATENTED LOADSHIFT TILTING SYSTEM. The unique push-slide-secure automatic locking system eliminates the need for inefficient, wear sensitive, foot-operated or hand controlled jaws. The light yellow colored foam filled tires are maintenance free and leave no traces. It comes in powder coated steel (robotic welding) with high strength components.



Specifications

Height =	54.5 in
Width =	24 in
Depth =	27.4 in
Range Ø =	up to 30 in
Weight	485 lbs
Capacity	45 lbs

Main features

- SUPERIOR ERGONOMICS
- Flat-free tires leave no stripes
- Handles tires and wheel assemblies



Y471123 - Smart Disc

Keep those wheel sets mobile in your showroom and workshop! Stack, roll and grab them with (or without) your Smart Cart.

Specifications

Ø	26.7 in
Weight	353 lbs
Capacity	8.2 lbs



Y472270 - Wheel Assist ERGO+

Operating as a standalone piece of workshop equipment, that doesn't require charging or linking up to a power source, the Winntec® Wheel Assist has powerful gas springs that enable workshop technicians to quickly and easily remove and replace wheels while in an ergonomically correct position (chest height). This unique, patent-pending product, allows the operator to install wheels at chest height.

Specifications

Height	70.9 in
Width	27 in
Weight	99 lbs
Capacity	93 lbs

Main features

- PROFESSIONAL'S CHOICE
- The power of simplicity
- Maintenance free
- Fender protection

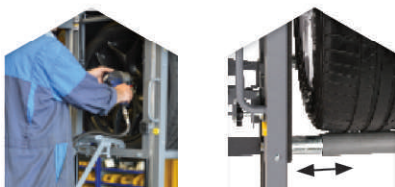
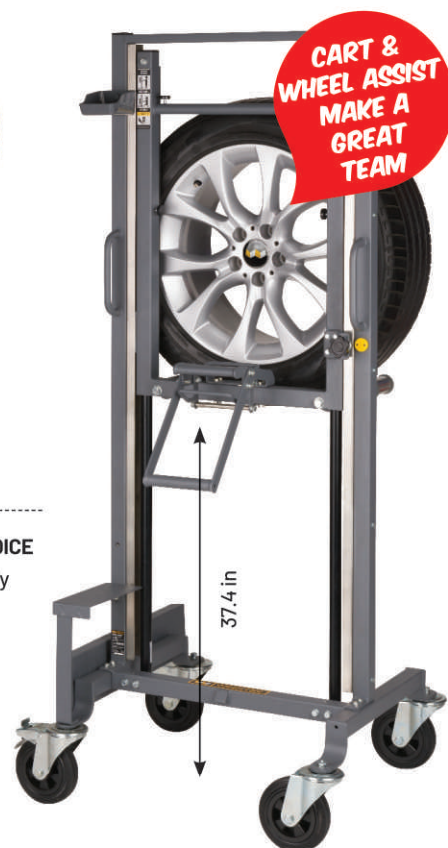



Y471105HD - Wheel Dolly



This industrial quality wheel dolly increases productivity in the shop by offering a fast & efficient way to remove tire/wheel assemblies. Its ergonomic design helps to reduce back strain injuries.

The extended rollers (ideal with wide base tires) can be installed in 3 positions depending on the wheel size. The rubber wheels have an all new and unique steel core providing optimal life time performance.

Main features

- QUICK DETACH HANDLE
- Extended rollers - 11.4in

Specifications

Frame width	27.6 in
Handle length	39.4 in
	485 lbs
	33 lbs

HELPS PREVENT BACK INJURIES



MOBILE TRUCK SERVICE

Y471106 - SAFERGO Truck Wheel Dolly

This lightweight, portable dolly has a compact hydraulic unit that ensures precise positioning. It also allows the operator to work on a very short distance from the vehicle which is crucial during road assistance service work.

Its shock absorbing casters ensure a smooth ride from and to the hub on a rough surface. Affordable ergonomics without affecting operation speed.



Main features

- CARRY HANDLE & BELT
- Maximum mobility
- Fast positioning



WATCH DEMO

Specifications

Frame width	35.4 in
Frame depth	17.7 in
Frame height	12.2 in
	352.75 lbs
	64 lbs

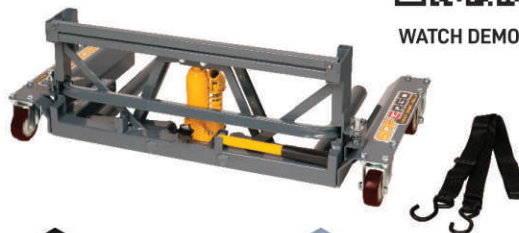

Lifting Equipment

Y411202 - Lightweight Alu/Steel Jack

Light weight design combined with TURBO LIFTER technology. The PU wheels minimize noise and potential (showroom) floor damage. The jack starts at 3.4in and reaches 16.5in maximum height.

Main features

- 2 SPEED LOWERING
- Light weight
- Turbo Lifter System
- Foot pedal
- PU wheels
- Rubber pad



Specifications

Min. H. =	3.4 in
Max H. =	16.5 in
Width =	11.1 in
Length =	24.6 in
Weight	2 T
KG	48.5 lbs

Y420303 - Turbo Lift Jack 3T

This jack is equipped with Winntecs unique TURBO LIFTER system, rubber pad and handle bumper. The professional universal joint release valve makes it possible to lower the jack with load very precisely and free of any risks. The heat-treated chromed pump pistons (protected with jacket to prevent from dirt intrusion) are placed at a 45° angle so a complete pumping stroke will always be utilized. Also the main ram has a chrome plating which ensures maximum durability.

Main features

- TURBO LIFT SYSTEM
- PU Pad
- Steel wheels
- Extremely stable



Specifications

Min. H. =	5.1 in
Max H. =	19.3 in
Width =	14.9 in
Length =	28.7 in
Weight	2 T
KG	90.4 lbs





Y432024 - Single Stage Air Service Jack 24T

This single stage air service jack delivers a massive 24 Ton of power and comes with premium interior hydraulic and pneumatic components. It is designed to meet and exceed expectations of a quality jack at a very competitive market value. The controller allows for the jack to ascend and descend with air. No more relatively unsafe, manual descending of heavy trucks! This Y432024 comes with 3 extensions (0.81, 2 and 4 inches) and is equipped with a 3.3in extension screw. The heavy duty wheels have been designed for daily use.

Main features

- **HARD CHROMED PISTON**
- Pneumatic descend
- Dead-man control
- Extension screw

Model	A	B	C	D	E	F	G		
Y432024	8.5	5.6	3.3	20.7	48.8	10.4	17.4	24 T	88.2 lbs
Y432032	5.9	2.3	2.6	18.9	51.2	11.4	11.3	32/16 T	83.8 lbs

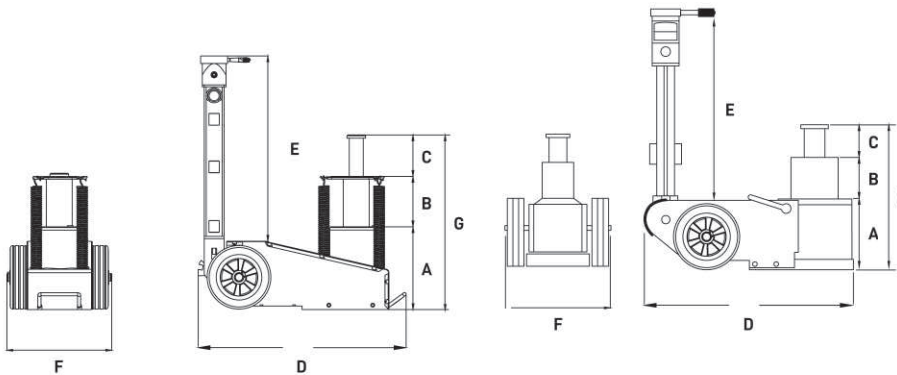

**AIR
CONTROLLED
DESCENT**



Y432032 - Telescopic Air Service Jack 32T

Dual stage air service jack with a low entrance height of just 150mm and hard chromed piston. With 32/16 Ton capacity and its compact dimensions, this jack is ideal for both workshop and road assistance duty.

The controller allows the jack to ascend and descend with air. Air controlled descent ensures maximum safety while dealing with heavy loads.

This Y432032 comes with 2 extensions (1.75in and 4in). As an option we offer a 10.25in extension which is a great help when lifting trailers.

Main features

- **CHROMED PISTONS**
- 5.9in entry height
- Compact body

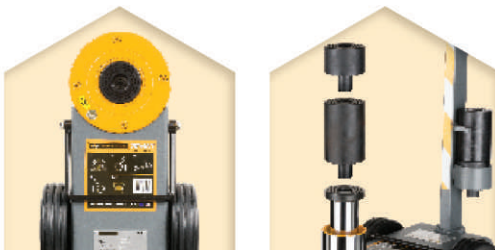

**LOW
CLEARANCE
-
MAXIMUM
MOBILITY**



GT260MM-EXT

Extension 10.25in for Y432032



Bottle Jacks

Versatile for use in a large variety of applications: pushing, bending, pressing or straightening. The full range comes with cast iron bases, polished main rams and a solid, chromed pump linkage. These jacks are tested to the latest European standards, have overload protection and can be used in both horizontal and vertical positions. All models (except Y413000 & Y411000) have a twist top for precise height adjustments.

The telescopic Y411000 comes with two extensions (1.8in - 0.25in), internally machined oil passages, smooth bearing surfaces and close tolerances.



Main features

- CHROMED PISTONS
- Easy maintenance
- Heat-treated saddle

Jack dimensions

Model	Base plate (in)	Min H. (in)	Lifting H. (in)	Adjust H. (in)	Max H. (in)	✋	⚖️ (lbs)
Y410200	3.8*3.6	6.2	3.5	2.4	12.1	2 T	5.0
Y410400	4.4*4.1	7.1	4.3	2.4	13.8	4 T	7.25
Y410600	4.6*4.6	7.75	4.9	2.4	15.0	6 T	9.7
Y410800	4.7*4.7	8.1	4.9	2.4	15.4	8 T	11.9
Y411000	7.1*4.6	4.7	3.9	-	10.2	10 T	14.1
Y411200	5.5*5.3	8.4	4.9	2.4	15.7	12 T	15.9
Y411500	5.5*5.5	8.9	5.5	2.4	16.7	16 T	18.3
Y412000	6.1*5.5	9.6	5.7	2.4	17.7	20 T	23.1
Y412001	6.1*5.5	7.5	3.5	2.4	13.4	20 T	19.8
Y413000	6.9*6.3	11.2	7.0	-	18.3	30 T	32.2

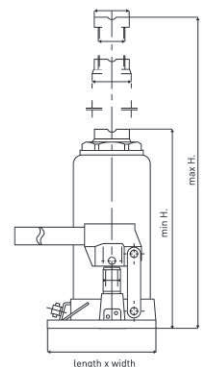

Air Bottle Jacks

Premium quality 20T air & air/manual bottle jacks. These models feature a aluminum air motor, specially heat treated cylinder walls and chrome pistons ensuring premium performance, durability, life and safety. Filters prevent contaminates from entering the air/hydraulic system.



Main features

- **WELDED BASE**
- Extension screw
- High speed air motor
- Chromed ram

LOW PROFILE



Y432021 - Low Profile Air Bottle Jack 20T

Low Profile Jack with a 20 Ton capacity. This unit includes a welded base to prolong service. Chrome main ram and aluminum air motor guarantee optimum lifetime. Air filter and air regulator connected to hose, included. Does not offer a manually operated pump.

Y432020 - Air Bottle Jack 20T

The Heavy Duty Series Jacks are among the toughest in the market. Each comes equipped with an air regulator, a chrome ram, a welded base, and return springs so that these jacks will keep on working no matter the job. Each unit is also hand-tested before shipping to guarantee maximum reliability.



BEST IN CLASS



Y432003 - Air Bottle Jack On Trolley 20T

20 Ton air/manual bottle jack with trolley, allowing you to store the jack vertically. This model features a specially heat treated cylinder wall and chrome piston, ensuring premium performance and durability. Can be stored vertically.

Model	Base plate (in)	Min H. (in)	Lifting H. (in)	Adjust H. (in)	Max H. (in)	(kg)	(lbs)
Y432021	7.1*4.5	5.8	2.6	1.8	10.2	20 T	19.8
Y432020	8.7*6.9	9.6	5.9	3.15	18.7	20 T	36.4
Y432003	11.8*5.9	10	5.9	3.15	19	20 T	56.7

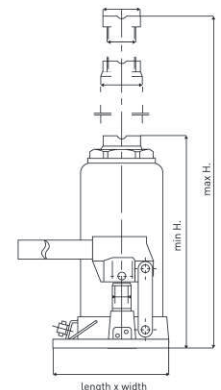

Workshop Equipment

Jack Stands

Choose from a selection of heavy-duty jack stands with either ratchet-type or pin-type support columns, both of which provide comfortable support and flexibility via heavy-duty contact saddles and wide feet. A must-have in all garages and workshops.

Y450301 - Jack Stand 3T

Main features

- RATCHET TYPE
- Base with foot pads
- Positive lock
- Carrying handle



Y451600 - Jack Stand 6T

Main features

- RATCHET TYPE
- Base with foot pads
- Positive lock
- Carrying handle



Y451205 - Low Profile Jack Stand Set 12T

Low profile jack stand with handle and wheels for easy positioning under the vehicle. The pin type support column adjusts to five different height positions. An 8.7in square base secures and stabilizes load.

Main features

- PIN TYPE
- Nylon wheels
- Handle low profile

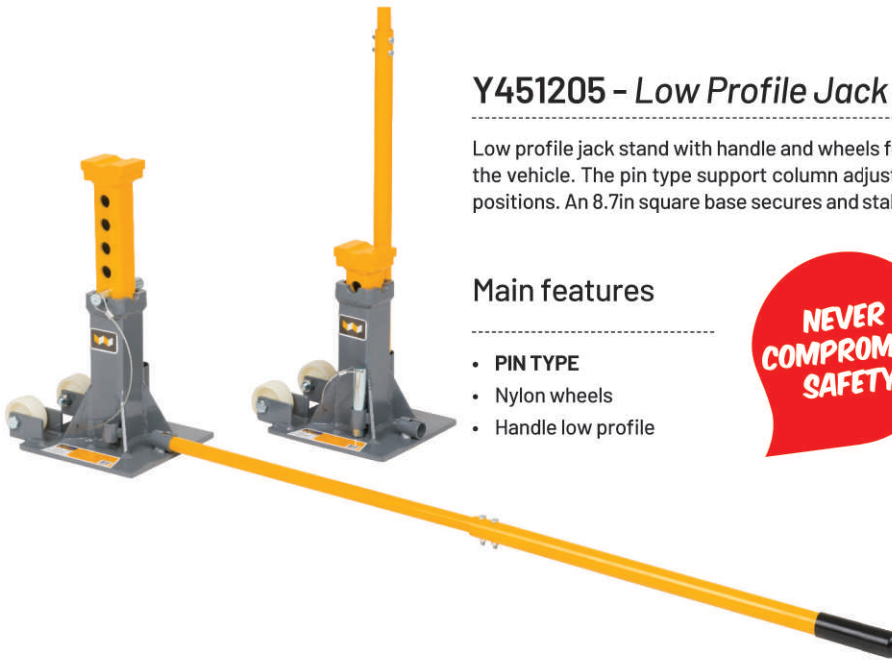

Y452205 - Low Profile High Capacity Jack Stand Set 22T

Heavy duty, welded, wheeled jack stand set with detachable handle. Multi-angle handle sockets ensure easy storage and safe positioning under the vehicle.

Model	Min H. (in)	Max H. (in)	W (in)	L (in)	Capacity (T)	Weight (lbs)
Y450301	12	17.7	7.3	8.0	3 T	15
Y451600	15.6	24.6	10.4	11.5	6 T	30.5
Y451205	11.9	17.7	11	8.7	12 T	44.1
Y452205	15.8	22.6	13.1	11	22 T	93.5

Y490000 - Liftpad X

LIFTPAD helps to lift safely & reduces the risk of damaging your vehicle's chassis and lifting point! Works with most floor jacks.

Perfect fit guaranteed with Winntec models:
Y411202, Y420250, Y420303, Y420330, Y420333, Y420336.

Main features

- UNIVERSAL FIT
- PFAS & PAHS FREE
- Avoids frame rail damages
- Avoids lift point deformation



MADE OF SUPER STRONG
Ultra High Molecular Weight Polyethylene

Specifications

Top Ø =	4.80 in
Height =	0.80 in
4 Base slots Ø =	3.60 in 4.10 in 4.20 in 4.65 in
X-groove =	0.4/0.5 in
Weight	1 lb

Y471150 - Air Hydraulic Pump 1600 cc

For use with a variety of rams, presses and hydraulic tools operating up to 700bar/10,000 psi. Air exhaust muffler for quiet operation. Aluminum housing.

Two stage release mechanism; pump, hold or release with pedal control. Air inlet 1/4, outlet 3/8. Working pressure 6-10 bar. Weight: 17.4 lbs.



Y471120 - Hydraulic Combi Bead Breaker - 5T

Designed to work on all single, two and three pieces 2-5-10 hole buds, 7.50x16s and all tubeless tire/rims. Includes 3 claws. Working range up to 120mm. Self-retracting. Durable anti-corrosive finish.



Y478205 - Hose Assembly 2.5m (= 8.2 ft)

Compatible with Y471150 and Winntec Bead Breaker model Y471120.

Y471180 - Wheel Removal kit

This ready-to-use kit includes a case, cylinder, pump, hose and a variation of adaptors to be installed depending on the space between the wheel and the chassis of the vehicle. With 10 Ton of hydraulic power and manual control of the foot pump, it becomes a safe and quick job to press the oxidized wheel from the vehicle.

Main features

- ALL-IN-ONE SOLUTION
- Foot operated
- Metal case

Specifications	
Height =	6 in*
Width =	18.9 in*
Depth =	9.25 in*
Force	10 T
Weight	33 lbs

* Case Dimensions



AVOIDS INJURIES & SAVES TIME

FAST LOCK JACK BLOCK



Y450350 / Y450351 - Fast Lock Jack Block 3.5T

The Fast Lock Jack Block is the ultimate solution for transforming your floor jack quickly into a secure jack stand. It extends 8.5in to 13.5in and is equipped with a spring release for easy positioning. Must Have for quickly and safely supporting all kinds of vehicles. Especially those that don't show multiple lift/support points.

Highly recommended for those workshops and mobile operators that service EV's.



WATCH DEMO

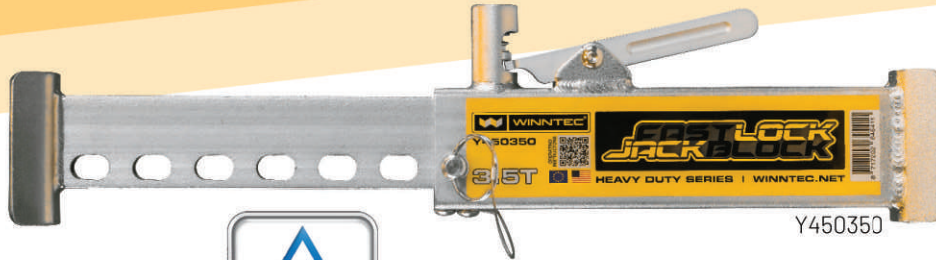

Y450350



Y450351

Specifications

Min. H =	8.5 in
Max. H =	13.5 in
Weight	3,5 T
KG	3.75 lbs

Check out our Winntechnology videos, highlighting our distinctive technologies.



JTM200010 - Mobile Energy & Air

This mobile battery booster is an indispensable tool for your boat, motorhome, caravan or car. It is also an ideal product for car dealers and can be used daily in your workshop, showroom and car park.

Main features

- START BOOSTER 2000A
- Compressor auto-start-stop 10 bar / 145 PSI
- High capacity power bank 55.5 wh
- Multifunctional LED light







Upon Request

Y471148 HD Dominator - Smart Cart

UPON REQUEST

Our new Smart Cart with PATENTED LOADSHIFT TILTING SYSTEM, suits tire techs that transport tires and wheel sets all day long in and around the shop and at racetracks. It picks up even bigger wheels, while its integrated kick pedal ensures a quick release of 'the load'. The redesigned, stronger, sleeker arms in stainless, guarantee a perfect catch and grip of the heaviest wheelsets. Includes a bracket set to install a Smart Disc at the back of the frame.

Main features

- **AUTO-OPEN/CLOSE STAINLESS GRIPPERS WITH FLOOR PROTECTORS**
- Handles tires and wheel assemblies
- Minimized required clearance (2 inches) between tire stacks
- Automatically activated and patented LOADSHIFT technology requires 3 times less effort to tilt/lift on average
- Solid rubber wheels with an aluminium core and industrial ball bearings
- Height-adjustable top plate with rubber grips
- Foot Control Bar to better manoeuvre while tilting/placing the load
- Spring-operated kick pedal
- Superior ergonomics



RIVIAN R1T
275/50/R22
WHEEL DIAMETER
32.7 INCHES
EFFORTLESS!

BMW XM
315/30/R23
WHEEL DIAMETER
30 INCHES
EFFORTLESS!

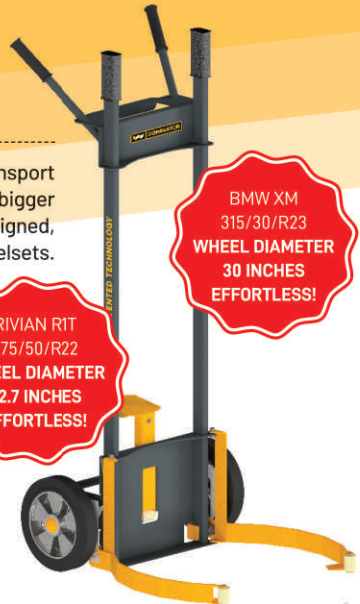

Specifications

Height =	54.5 in
Width =	24 in
Depth =	27.4 in
Range Ø =	up to 32.7 in
lbs	485 lbs
KG	51.4 lbs

Y471148 EXT - Extender Kit

UPON REQUEST

OPTIONAL bolt-on/off extender with rubber grips to increase the carrying capacity of the DOMINATOR to 8 tires. Highly recommended for those who transport large stacks of tires.



JTM400000 - Mechanic's Seat

UPON REQUEST

The JTM400000 is the ideal addition to any garage or detailer! Perfect for precise detailing of wheels, tires, exhaust tips, and more, or for use in paint repair and polishing of side panels, bumpers, and lights!

Main features

- **CARBON STEEL INNER FRAMING**
- Premium swivel casters with 2 locks
- Comfortable height
- Cradle style seating with onboard storage
- Seat dimensions: 18 x 10 in



Specifications

Width =	16.6 in
Length =	25.3 in
Height =	13.1 in
lbs	286.6 lbs
KG	12 lbs



M499440 - Foldable Creeper/Seat UPON REQUEST

Extra long, foldable workshop creeper/seat with 7 heavy duty wheels for easy maneuverability. Thick padded cushions create a comfortable base for easy access and movement during your maintenance tasks.

Main features

- **EXTRA LONG (47.25 x 16.1 x 5.5 in)**
- Capacity of 253.5 lbs
- Only 26.5 lbs!



JTM220000 - Hydraulic Jack 2.2T UPON REQUEST

2,2T Hydraulic Jack from the Jack The Mech series with heavy duty steel construction, handle bumper and polyamide wheels.

Main features

- **RUGGED UNIVERSAL JOINT FOR PRECISE LOAD CONTROL**
- Two-piece detachable handle
- Dual piston pump and foot pedal for easy lifting
- Wide front wheels provide load control



Specifications

Width =	13.4 in
Length =	27.6 in
Min. H. =	3 in
Max H. =	18.4 in
2,2 T	
63 lbs	



JTM300000 - Hydraulic Jack 3T UPON REQUEST

3T Hydraulic Jack from the Jack The Mech series with heavy duty steel construction, handle bumper and polyamide wheels.

Main features

- **RUGGED UNIVERSAL JOINT FOR PRECISE LOAD CONTROL**
- Two-piece detachable handle
- Dual piston pump for fast lifting
- Wide front wheels provide load control
- Rubber saddle pad



Specifications



Width =	13.2 in
Length =	24.2 in
Min. H. =	5.1 in
Max H. =	18.5 in
3 T	
68.4 lbs	



Y411350 - Full Aluminum Jack UPON REQUEST

Winntec's popular aluminum floor jack has been dominating the European market for the last 20 years. The ball bearing-mounted rear wheels and wide track front wheels provide easy maneuverability and stability under load. A newly designed saddle pad (according to regulations of several European car makers) protects the vehicles bodywork and components.

Thick frame side plates and a reinforced lift arm result in added strength. A bypass and overload valve prevent from over-extension of hydraulic ram and jack use beyond rated capacity. The two-piece handle with quick lock offers easy storage. Heavy duty nylon wheels keep the jack's general weight below 10kg.

Specifications	
Min. H. =	3.1 in
Max H. =	14.75 in
Width =	9.3 in
Length =	19.7 in
 T	1,35 T
 KG	22 lbs

Main features

- **JUST 22 lbs**
- Nylon wheels
- Rubber pad



M411355 - Compact Winntec Motionline Jack UPON REQUEST



Designed for the pro - available to all!

A low, lightweight and compact aluminium garage jack; only 31lbs. Equipped with TURBO LIFTER and 2-SPEED LOWERING, a rubber protective pad and a removable handle. Advanced features at a consumer price point.

Main features

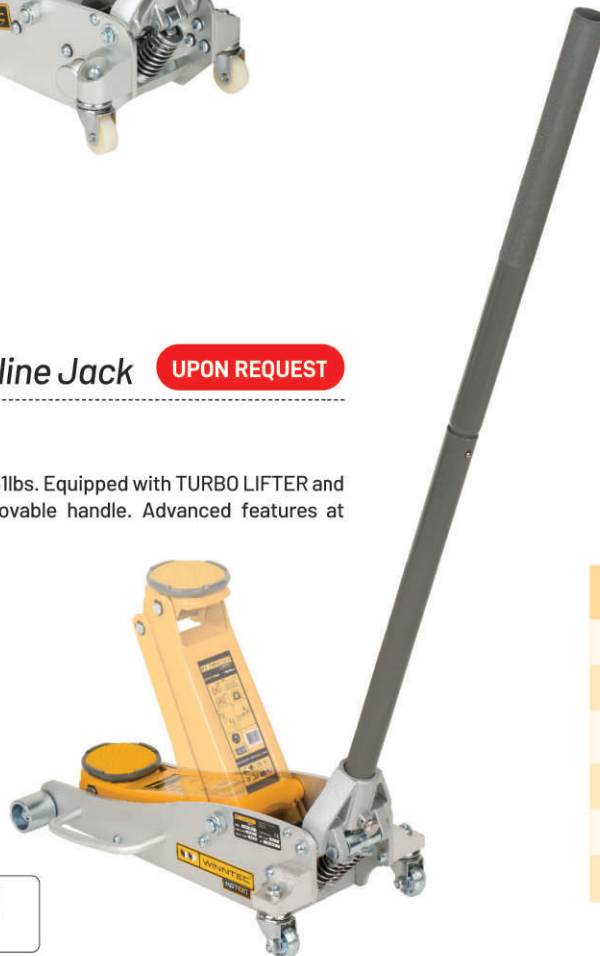
- **2 SPEED LOWERING**
- Ultra light jack
- Turbo Lifter System
- Color box
- Rubber pad



Specifications	
Min. H. =	3.5 in
Max H. =	14.2 in
Width =	9.7 in
Length =	18.9 in
 T	1,5 T
 KG	31 lbs



Y420222 - Low Profile Jack Stand Jack UPON REQUEST

Low profile jack with integrated jack stand function and hold to run control. 3in entrance height, Turbo Lifter, handle bumper.

Main features

- 2 SPEED LOWERING
- ULTIMATE SAFETY
- Auto lock
- Low profile
- Foot pedal
- Turbo Lifter System
- Hard chromed ram and pistons
- Rubber pad



WATCH DEMO

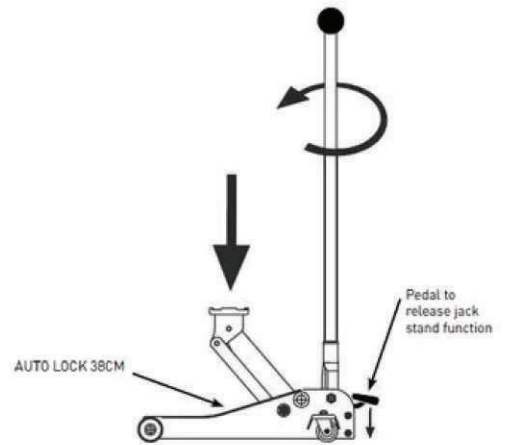

Specifications

Min. H. =	3 in
Max H. =	19.7 in
Width =	13.75 in
Length =	27.75 in
Weight	2 T
Weight	92.6 lbs



Y420250 - Low Floor Jack 2T

UPON REQUEST

Ultra low profile design combined with TURBO LIFTER technology. The PU wheels minimize noise and potential (showroom) floor damage. The jack starts at 3in and reaches an impressive 20in at maximum height.

A rubber grip and saddle are standard features. This low profile jack comes with heat-treated chromed pump pistons and chromed main ram.

Main features

- 2 SPEED LOWERING
- Turbo Lifter System
- Ultra low - 3in
- PU wheels
- Rubber pad



Y490000
GUARANTEED
PERFECT
FIT!
Y490010EV

Specifications	
Min. H. =	3 in
Max H. =	20 in
Width =	13.5 in
Length =	27 in
T	2 T
KG	72 lbs

OUR
BEST
GOT EVEN
BETTER!

Y420330 - Low Floor Jack 3T (US)

UPON REQUEST

Ideally configured for car dealers and universal workshops. The jack comes with noise reducing PU wheels, a rubber pad/grip and our TURBO LIFTER pump system. With a minimum height of 4.7in and its compact size, this 3T jack is the right choice for car dealerships that look for attractive pricing, functionality and safety.

The release valve allows you to lower heavy loads in a controlled way. The main ram and both pistons are chrome plated. WinnTec selected the best industrial grade seals and gaskets for its next best seller.

Main features

- 2 SPEED LOWERING
- Turbo Lifter System
- PU wheels
- Rubber pad



Specifications	
Min. H. =	4.7 in
Max H. =	17.7 in
Width =	13.5 in
Length =	24.3 in
T	3 T (US)
KG	68.3 lbs



Y490000
GUARANTEED
PERFECT
FIT!
Y490010EV

EXCELLENT
PRICE -
QUALITY
RATIO

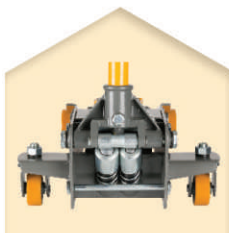

Y420333 - Low Floor Jack 3T

UPON REQUEST

This jack offers the best possible specifications, which unites the ultra low profile design and high reach, our unique **2 SPEED LOWERING** technology, **TURBO LIFTER** pump system, 3T capacity and noise reducing PU wheels. The highest quality of components will ensure maximum performance and life time.

Main features

- **2 SPEED LOWERING**
- Low profile
- Turbo Lifter System
- PU wheels
- Rubber pad
- Foot pedal



Specifications

Min. H. =	3 in
Max H. =	16.8 in
Width =	13.6 in
Length =	26.5 in
Weight	3 T
Weight	82 lbs



WATCH DEMO

Y420336 - Low Floor Jack 3.6T

UPON REQUEST

Its 3.6T capacity and low entry height combined with a high reach of 21,3in set this jack apart from its competitors. A rubber grip, rubber pad and handle bumper are included. The jack benefits from a fully welded power unit that shows chromed pistons and chromed main ram. Equipped with industrial quality polyamide wheels, dual speed lowering and TURBO LIFTER technology.

Main features

- **2 SPEED LOWERING**
- Turbo Lifter System
- Rubber grip
- Polyamide wheels
- Rubber pad
- Welded pump



MAX HEIGHT 540MM



Specifications

Min. H. =	3.75 in
Max H. =	21.3 in
Width =	13.75 in
Length =	27 in
Weight	3,6 T
Weight	85 lbs

Long Chassis Jacks

Designed specifically for extreme heavy-duty lifting and perfect for servicing truck fleets, busses, farm- and heavy construction equipment, perfect for vehicles that require a low starting point and a relatively high reach. All models feature a foot-operated pump for quicker lifting, an automatic overload safety valve and swivel casters for easy maneuvering. The ergonomic handle features an integrated load control knob which is connected to a universal joint release valve.



Y420200 - HD Jack 2T UPON REQUEST

Built for heavy duty lifting. Equipped with foot pedal and ergonomically designed handle with release button, lowering the jack gradually.



Y420301 - HD Jack 3T UPON REQUEST

Built for heavy duty lifting. An automatic overload safety valve, efficient foot operated pump and swivel castors are standard.



Y420500 - HD Jack 5T UPON REQUEST

New ultra-long garage jack models with ergonomic handle, foot pedal, automatic overload safety valve and swivel castors.





Y421000 - HD Jack 10T UPON REQUEST

Built for heavy duty lifting. An automatic overload safety valve, efficient foot operated pump and swivel castors are standard.



Jack dimensions

A = Min. Height (in) B = Max. Height (in) C = Width (in) D = Length (in) E = Height (in)

Model	A	B	C	D	E	 T	 KG
Y420200	5.4	31.5	15.6	51.6	50.6	2 T	128 lbs
Y420301	5.1	23.6	12.8	55.1	52.4	3 T	143 lbs
Y420500	5.9	26.8	14.4	59.25	53	5 T	198.4 lbs
Y421000	6.3	26.8	19.1	64.4	53.3	10 T	320 lbs

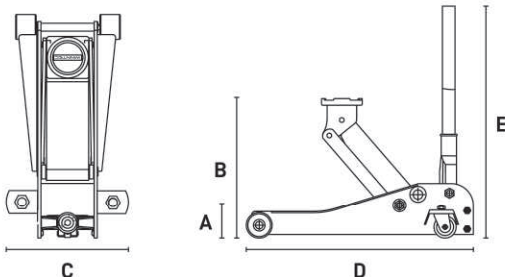



Pneumatic Balloon Jacks

These pneumatic balloon jacks have an internal telescopic stabilizer (ASTM-513 steel) providing lateral and vertical stability. A safety valve prevents from over inflation. Light weight Winntec® balloon jacks are the preferred choice of tire shops and body shops because they can be easily placed on lifts. Moreover, these jacks lift extremely fast ensuring quick wheel changes.

Y422002 **UPON REQUEST**

- IDEAL ON 4 POST LIFT
- PU pad
- Low profile
- 2 Stage



Specifications Y422002

A =	11.8 in	A' =	14.2 in
B =	5 in	B' =	7.3 in
D =	15.75 in		
	2 T		
	32.6 lbs		

Y422012 **UPON REQUEST**

- PUPAD
- Low profile
- Store upright
- 2 Stage



Specifications Y422012

A =	11.8 in	A' =	14.2 in
B =	5 in	B' =	7.3 in
D =	43.3 in		
E =	11 in		
	2 T		
	35.3 lbs		



EXPLORING WINNTECHNOLOGY

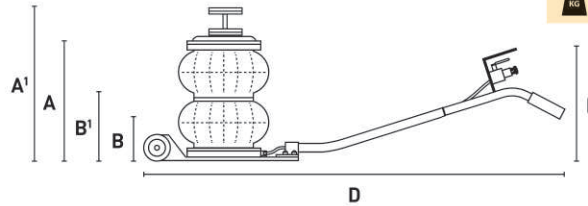
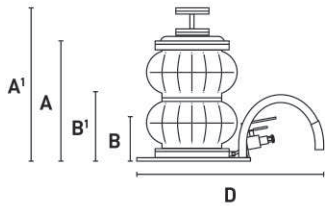

Y454000 - Fork Lift Tractor Jack **UPON REQUEST**

Winntec® forklift jack with dual lifting points (4/5T), double speed function without load, chromed ram and chromed pump piston. Lower, extended arm is only 2.6in for easy access under forklift trucks. The upright piston at 16.4in is ideal for lifting tractors and farm machinery. Hydraulic lift 14in on forklift arm and 13.8in on upright piston. Special designed hydraulic pump with Japanese seal kits and overload valve. Removable handle and compact size.

Main features

- 2-POSITION LIFT PAD
- High-strength frame work

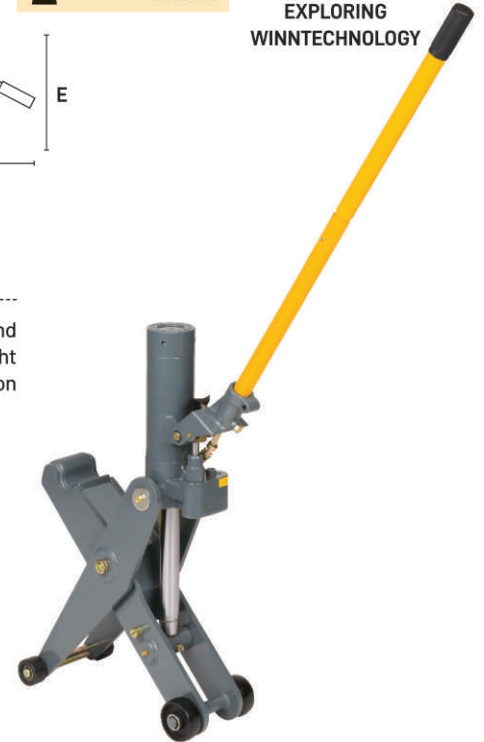
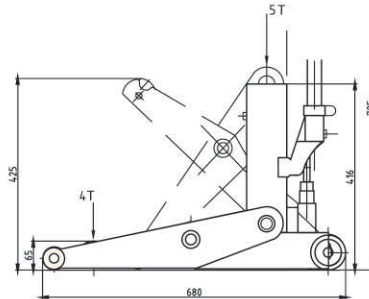

Model	Max H. (in)	Min H. (in)	Length (in)	Height (in)		(lbs)
Y454000	16.7	2.6	26.8	28.5	4-5 T	99

Y452330 - 3T

UPON REQUEST

Our toughest stand offers a large base of 12.2in ensuring maximum stability. The stand is equipped with a thick, round, replaceable rubber pad showing a diameter of 4in.



JUST 11.8 IN
MIN. HEIGHT
RECOMMENDED FOR
MODEL 3 &
MACH-E



Main features

- REPLACEABLE RUBBER PAD
- Low-profile
- Stable base (12.2 in)

Y452300 - 3T

UPON REQUEST

- PIN TYPE
- Large PU support pad



Y451206 - 12T High Reach

UPON REQUEST

Heavy duty, high reach welded jack stand with detachable handle, multi-angle handle socket and wheels for easy positioning under the vehicle.

The pin type support column adjusts to various height positions up to 38.2in making it suitable for both tire service and general trailer service jobs where chassis support is needed. Sold by single piece.

Main features

- NYLON WHEELS
- Pin type

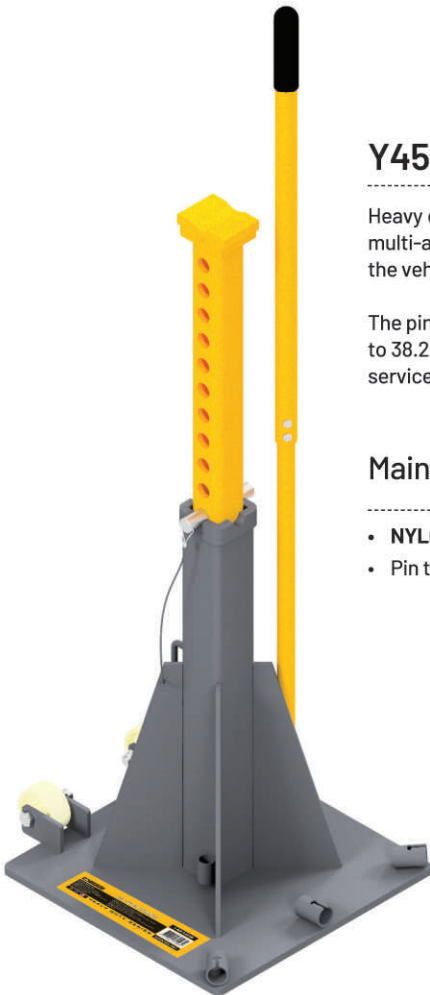

Y452600 - 6T

UPON REQUEST

- PIN TYPE
- Large PU support pad



Model	Min H. (in)	Max H. (in)	W (in)	L (in)	Ø (in)	(T)	(lbs)
Y452300	12.7	18.3	-	-	10	3 T	11.5
Y452330	11.8	17.75	11	-	12.2	3 T	20
Y452600	15.9	23.8	-	-	13.4	6 T	24.7
Y451206	23.7	38.2	16.7	14.6	13.4	12 T	64.4

Industrial Presses

Our range of presses with welded frame are suitable for standard pressing, bending, bonding and straightening jobs. Essential for the removal/installation of universal joints, bearings, pulleys, and wrist pins. 2 V-blocks for easy and secure positioning included.

Y461520 - Press 20T **UPON REQUEST**

- 2-SPEED HAND PUMP
- Sliding cylinder
- Feet with holes for fixation
- Optional: punch set & protection cover

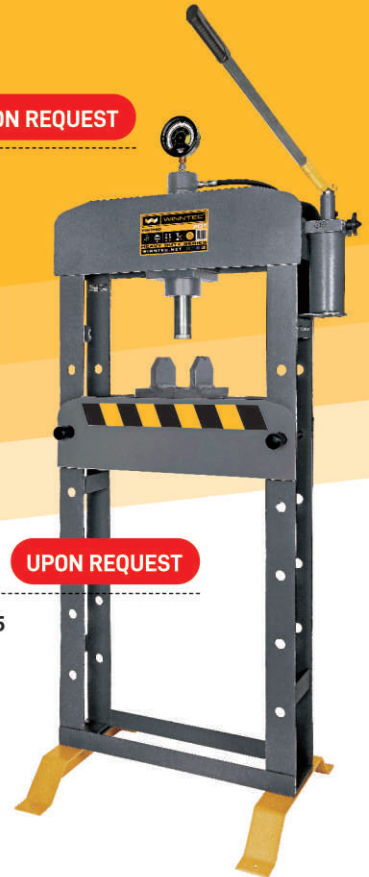

Y461516 - Bench Press 15T **UPON REQUEST**

- BENCH MODEL
- Double speed hand pump
- Sliding cylinder
- Feet with holes for fixation
- Optional: punch set



Y461533-PS - Punch Set **UPON REQUEST**

For Y461516, Y461520, Y461533 & Y461555



Y461555 - Press 50T **UPON REQUEST**

- 2-SPEED HAND PUMP
- Pneumatic foot operation
- Movable cylinder (left-right)
- Optional: punch set & protection cover

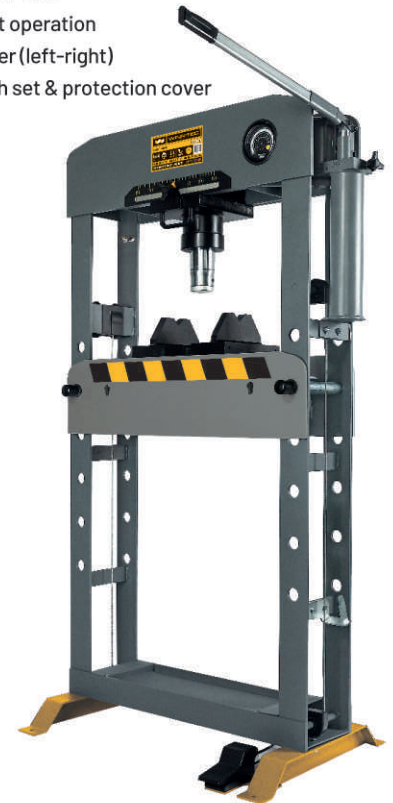

Y461533 - Press 30T **UPON REQUEST**

- 2-SPEED HAND PUMP
- Movable cylinder (left-right)
- Pneumatic foot operation
- Optional: punch set & protection cover

Y4615XX-PC - Protection Cover **UPON REQUEST**

For Y461516, Y461520, Y461533 & Y461555



Model	Height (in)	Depth (in)	Width (in)	T	(lbs)
Y461516	40	5.25	26.7	15 T	126.8
Y461520	72	21.25	33.5	20 T	222.7
Y461533	73	21.25	33.1	30 T	302
Y461555	73	25.6	42.5	50 T	538

Y444000/Y444100 - Collision Repair Set UPON REQUEST



Both 4T (Y444000) and 10T (Y441000) include solid blow cases, chromed rams/pistons and safety valves to prevent from overloading. Their heavy gauge snap-together pipework and cast attachments are compatible with most leading brands of body repair equipment.

Supplied with the following parts:

Single Speed Hand Pump • Cylinder (4in stroke Y444000 - 6in stroke Y444100) • Hose • Ram Flat Base • Spreader • 4in Extension Tube • 6in Extension Tube • 11.8in Extension Tube • 15.75in Extension Tube • Tube Coupling • Ram Toe • Wedge Head • Serrated Saddle • Flex Head • Plunger Toe • 90 Degrees Wedge Head • Storage Case.

Main features

- **QUICK LOCK FOR FAST (DIS)ASSEMBLY**
- Spring guards at hose end
- Thick walled extension tubes

Model	Cylinder (in)	 #	 (lbs)
Y444000	4	4 T	37.5
Y444100	6	10 T	68.3



Y4781155 - Single Acting 2-Speed 900 cc 70 Mpa UPON REQUEST

Light weight, high flow industrial pump with baked enamel finish to increase corrosion resistance. The compact design ensures efficient storage and transportation. Less handle effort to minimize operator's fatigue. Internal pressure relief valve prevents from overload situation.

Industrial 3/8-18NPT outlet.
Weight: 15 lbs

Y4781107 - Single Acting Cylinder 42-52mm (1.65 - 2.05in) 10T UPON REQUEST

High strength alloy steel for maximum safety and durability. Collar thread on high model enables easy fixture. Unique heavy duty spring provides fast piston return.

Industrial 3/8-18NPT connections.
Weight: 3.3 lbs



Y471120 - Hydraulic Combi Bead Breaker 5T UPON REQUEST

Designed to work on all single, two and three pieces 2-5-10 hole buds, 7.50x16s and all tubeless tire/rims. Includes 3 claws. Working range up to 4.7in. Self-retracting. Durable anti-corrosive finish.

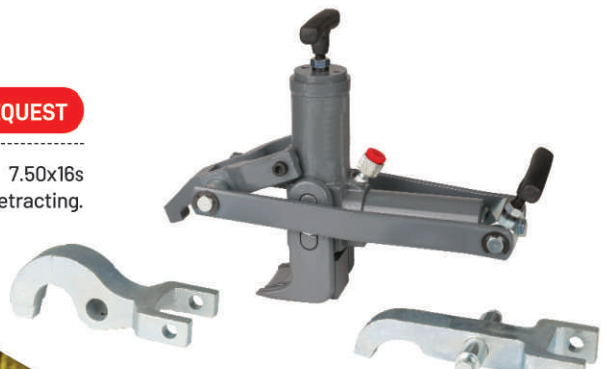

Y490010EV - Liftpad EV

UPON REQUEST

Liftpad EV is a must have accessory while lifting vehicles that require a lift adapter. The pad offers a 0.6in deep slot that shows a 3in diameter. The slot's dimensions ensure that the majority of brand specific lift adapters will fit. Liftpad is equipped with magnets at its base. The overall height of the pad is just 0.8in. Works with most floor jacks. **Perfect fit guaranteed with Winntec models Y411202, Y420250, Y420303, Y420330, Y420333, Y420336**

Main features

- COMPATIBLE WITH THE VAST MAJORITY OF ADAPTERS*
- PFAS & PAHS FREE
- Avoids costly damages
- MUST HAVE when lifting EV's

PFAS & PAHS FREE

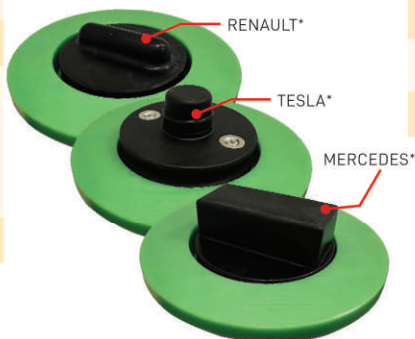

Specifications

Top Ø =	4.8 in
Height =	0.8 in
4 Base slots Ø =	3.6 in
	4.1 in
	4.2 in
	4.65 in
 Weight	0.3 lbs

* Adapters not included!

Y490020 - Liftpad

UPON REQUEST

LIFTPAD helps to lift safely & reduces the risk of damaging your vehicle's chassis and lifting point! Works with most smaller floor jacks. **Perfect fit guaranteed with Winntec models Y411350 & M411355.**

Main features

- UNIVERSAL FIT
- PFAS & PAHS FREE
- Avoids frame rail damages
- Avoids lift point deformation

PFAS & PAHS FREE

MADE OF SUPER STRONG
Ultra High Molecular Weight Polyethylene



Specifications

Top Ø =	4.33 in
Height =	1.67 in
Base Slot Ø =	3.15 in
X-Groove =	0.39/0.51 in

Check out our Winntechology videos, highlighting our distinctive technologies.



Rubber Saddles

UPON REQUEST

Y411350-42 - Fully Covering Saddle Pad Yellow

Perfect fit guaranteed with Winntec model: Y411350



Y420250-34 - Inlay Saddle Pad

Perfect fit guaranteed with Winntec models: Y420250, Y420330, Y420333



Y420336-42 - Inlay Saddle Pad

Perfect fit guaranteed with Winntec model: Y420336



Y491110 - Mechanic Gloves

A sturdy glove with protectors for professional work in the workshop.
Sizes: M - L - XL

Main features

- **IMPACT PROTECTION**
- Slip free silicone grip
- Double stitched
- Industrial hook and loop
- Machine washable



Y490025 - 2D XL Keychain



JTM120220 - 2D XL Keychain



Y490088 - Cap (L-XL)



Y491310 - Precision Gloves

Perfect for a variety of automotive service jobs that demand a 'fine touch'.
Sizes: L - XL

Main features

- **FINE TOUCH**
- Anti Slip
- Breathable stretch
- Abrasion resistant
- Terrycloth thumb
- Touch screen proof



Y490033 - Warmer/Cooler Lunch Bag

Compact and waterproof lunch bag.



M120110 - Smart Fast Charger

- **VEHICLE VOLTAGE INDICATOR 12-24V**
- USB-A 3.0 & USB-C
- Fast charging
- Alloy casing
- LED light



Y490022 - Waterproof Backpack XL

Our waterproof backpack protects your personal belongings, whatever the weather. The roll-top closure provides extra protection against the elements while you still have quick access to your belongings. The spacious main compartment offers ample storage space, while being splash-proof. The external zipper pocket contains your essential supplies such

Main features

- **100% PVC**
- Waterproof
- Floats
- Extra spacious



**GREAT
PROMO
ITEM!**

WINNTEC EUROPE

Rechtzaad 6
4703 RC Roosendaal
The Netherlands

WINNTEC USA

2255 W Morton Ave
Jacksonville, IL 62650
USA

WEB & EMAIL

Email usa@winntec.net
Web eu www.winntec.net
Web us www.gaihtertool.com

