



IMPORTANT

DURING TRANSPORTATION OR THE LIFTING OPERATION, AIR-BOUND MAY OCCUR. DO THE FOLLOWING STEPS TO BLEED AIR IF THE RAM PLUNGER IS PUMPED UP SLOWLY OR CAN NOT BE PUMPED UP.

1



OPEN THE RELEASE VALVE BY TURNING IT COUNTER CLOCKWISE FOR 2 ~ 3 TURNS.

2

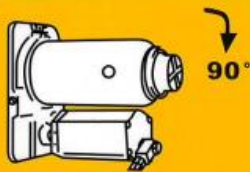

TURN THE JACK 90 DEGREE TO ITS HORIZONTAL POSITION. BE SURE THAT THE AIR MOTOR SHOULD BE UNDERNEATH THE RAM PLUNGER ASSEMBLY.

3



CONNECT THE AIR PISTOL TO THE AIR SOURCE AND PRESS THE AIR PISTOL FOR 20 SECONDS TO OPERATE THE JACK.

4

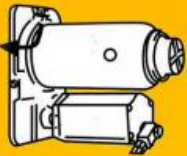

TIGHTEN THE RELEASE VALVE BY TURN IT CLOCKWISE WHILE THE JACK REMAINS AT ITS HORIZONTAL POSITION. IF THE RAM DOESN'T EXTEND, REPEAT ALL STEPS ABOVE.

AIR/HYD. JACK MAINTENANCE

MODELS: GT-20MS, GT-20MSLP, G432003, G432020, & G432021

- DISMANTLE THE SWIVEL CONNECTOR AND LUBRICATE THE AIR MOTOR BIWEEKLY.
- MAKE SURE THE AIR MOTOR IS PROPERLY ALIGNED TO THE BASE AND SECURE AS SHOWN ON PAGE 2.
- HOLD THE 17MM NUT LOCATED AT THE TOP OF THE SWIVEL CONNECTER AND TIGHTEN THE 1-1/4" NUT LOCATED DIRECTLY BELOW THE AIR MOTOR BY TURNING COUNTERCLOCKWISE.
- ALWAYS VERIFY THAT THE OIL LEVEL IS TOPPED OFF.

CHECK OUT THIS VIDEO LINK ["Bottle Jack Quick Tips"](#) OR GO TO GAITHERTOOL.COM FOR MORE INFORMATION



STANDARD HEIGHT

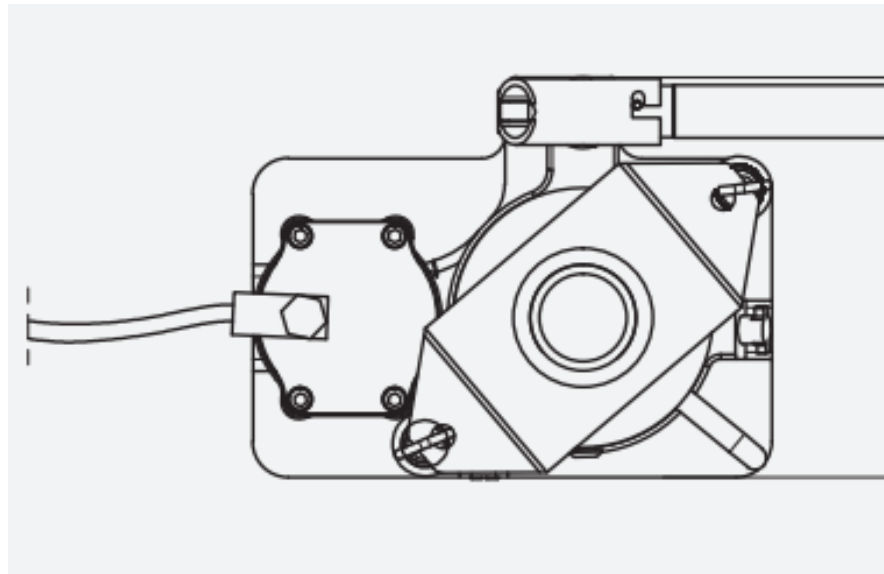
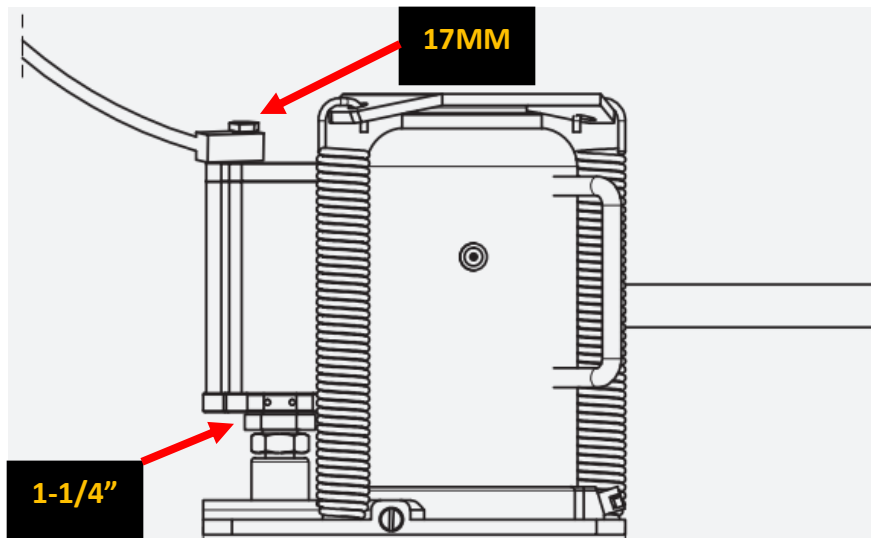

LOW-PROFILE

